

Motorized valve HM



GUANGZHOU SINON COMBUSTION
TECHNOLOGY CO., LTD.

☎ 020-39388398

☎ 020-39388310

🌐 www.gzsinoon.com

✉ sinon@gzsinoon.net

CHARACTERISTICS

- For safe shut-off of the supply of fuel gas or other gases.
- The valve will slowly open under the drive of internal oil pump when power on, and closes quickly when power off.
- With closed position feedback, the valve position can be monitored.
- Medium: natural gas, LPG, town gas, air and other clean gases.

APPLICATIONS

The motorized valve HM is mostly used for safe shut-off of gas main pipe in automatically controlled combustion system.

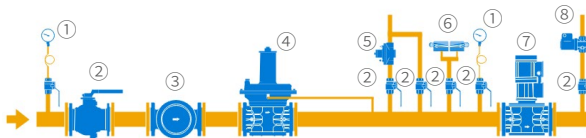

① Pressure gauge

② Manual shut-off valve

③ Gas filter SF

④ Gas pressure regulator GV

⑤ Relief valve SRV

⑥ Pressure switch GS

⑦ Motorized valve HM

⑧ Normally open solenoid valve SOV

SPECIFICATION

Technical parameters

- Normally closed valve, open when energized, close when de-energized.
- Opening time: ~ 10 s, closing time: <1 s.
- Power supply: 220~240 V AC, 50/60 Hz.
- Closed position feedback, dry contact, normally open or normally closed. Maximum contact capacity: 250 V, 2 A.

Type table

Type	HM	80	F	/1B	F
Dimensions	40: DN40	50: DN50	65: DN65		
	80: DN80	100: DN100	150: DN150		
Connection	R: Thread		F: Flange		
Max pressure	0.4B: 0.4bar		1B: 1bar	4B: 4bar	
Others	F: FKM diaphragm				

Pressure loss

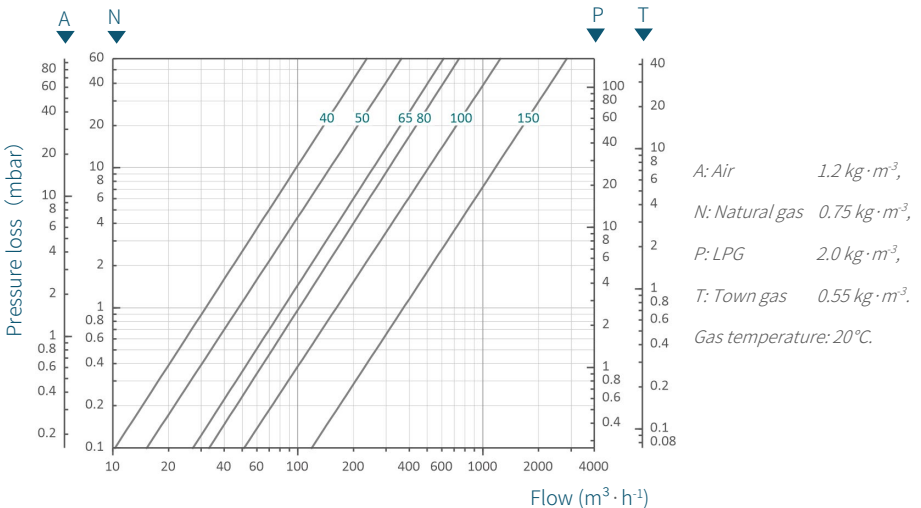

Dimensions

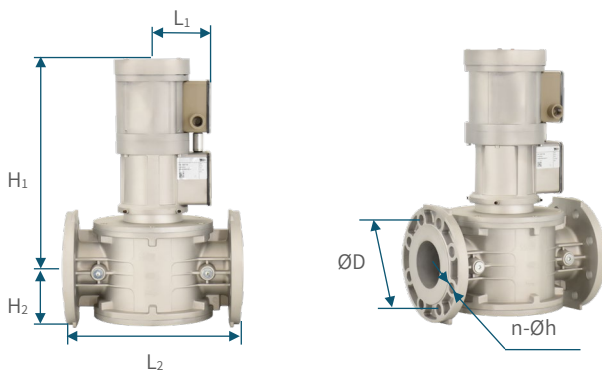

Type	Connection	L ₁ /mm	L ₂ /mm	H ₁ /mm	H ₂ /mm	D /mm	h /mm	n	Power /W
HM 40R/4B	Rp1 $\frac{1}{2}$ "	102	151	338	106	-	-	-	75
HM 40F/4B	DN 40	102	200	338	106	110	18	4	75
HM 50R/4B	Rp2"	102	182	349	117	-	-	-	75
HM 50F/4B	DN 50	102	230	349	117	125	18	4	75
HM 65F/1B	DN 65	102	310	372	93	145	18	4	75
HM 80F/1B	DN 80	102	310	372	100	160	18	8	75
HM 100F/1B	DN 100	102	350	397	115	180	18	8	75
HM 150F/0.4B	DN 150	102	435	427	142	240	22	8	75

When used for town gas, COG and other media containing corrosive components, please use the anticorrosion type HM..F, such as: HM 50R/1BF.

For flange connection, use plate flat-welded steel pipe flanges of PN 1.6 MPa in GB/T9119-2010 as mating flange.

INSTALLATION

- Installation position: in horizontal pipeline only, and the hydraulic head must be vertically upward.

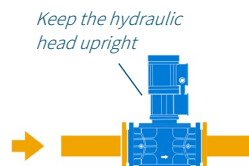

- The arrow on the valve body indicates the flow direction, determine the installation direction according to the arrow.
- Ambient temperature: -15~60 °C, install away from heat sources.
- Enclosure: IP 54. Prohibit installing the valve in the open air.

Wiring

- Connect the feedback, power and ground wire according to the markings on connection box.
- The cable is recommended to use 2.5 m² wire ear to connect with the terminal.

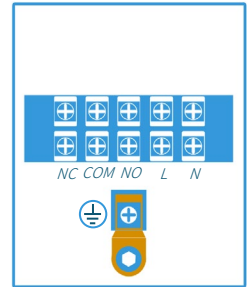

Attention

- The pipeline must be purged before installation. When installation, pay attention to the correct use of sealing materials such as PTFE tapes to prevent foreign matters from entering the valve.
- Do not weld the pipe around the valve after installing to prevent foreign matters from blocking or damaging the valve.
- A filter is recommended to be installed upstream to protect the valve from foreign matters, dust, etc.
- Do not exceed the max inlet pressure.
- The motorized valve is equipped with an anti-tilt protection device. When the hydraulic head is upside down or in the lying state, the valve will be de-energized and shut off automatically. The protection state will automatically cancel when the hydraulic head is pointing upwards.
- The motorized valve is equipped with a high-temperature protection device. When the temperature of hydraulic head is over 95 °C, it will be de-energized. When the temperature drops to operating temperature, the protection will automatically cancel.
- If the protection device cannot be restored or other problems occur, please return the valve to the manufacturer for maintenance.